

# CHRISTIE

## Modular Series Double Barbecue Cabinet

Christie's flat-packed Modular Series barbecue cabinets set the standard for pre-fabricated public barbecue surrounds. They are versatile, compact, easy to assemble, and very tough - to withstand continued use in the most demanding locations and harshest environments.

### KEY FEATURES:

- Hygienic stainless-steel benchtop with low-impact corner inserts for added safety
- Heavy duty aluminium concrete and stainless steel construction for ultimate durability and corrosion resistance
- Customize with panel colours, extra cabinet modules, cooktops and sink configurations
- Select additional access doors for extra storage
- Shipped flat-packed for easy site access and reduced freight costs
- Fast, simple assembly by any competent person
- Grease trap for ease of removal & cleaning



Product shown with our CC2 electric cooktop. Double cabinets can also be ordered with our natural gas and LPG configured cooktops.

Modular barbecue frames and doors are powder coated in Aztec Silver as standard for maximum durability. Custom colours are available at additional cost.

### STANDARD COLOUR OPTIONS:



Custom panel are available and may incur additional cost.

### OPTIONS:



# Christie Modular Series Double Barbecue Cabinet

## DIMENSIONS:

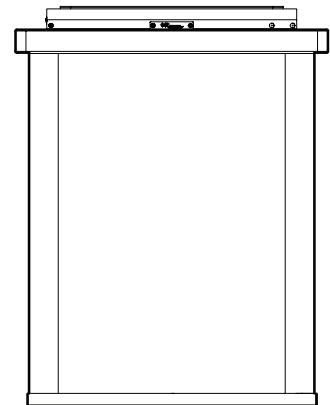
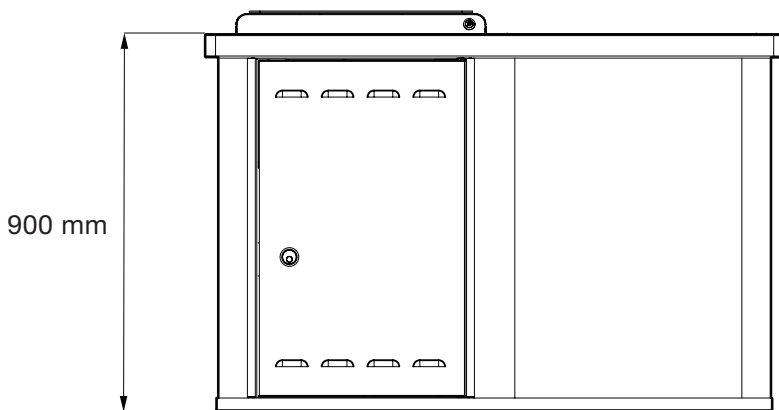
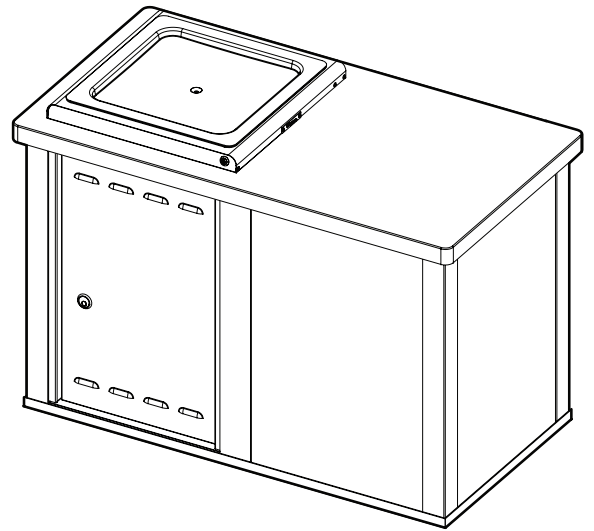
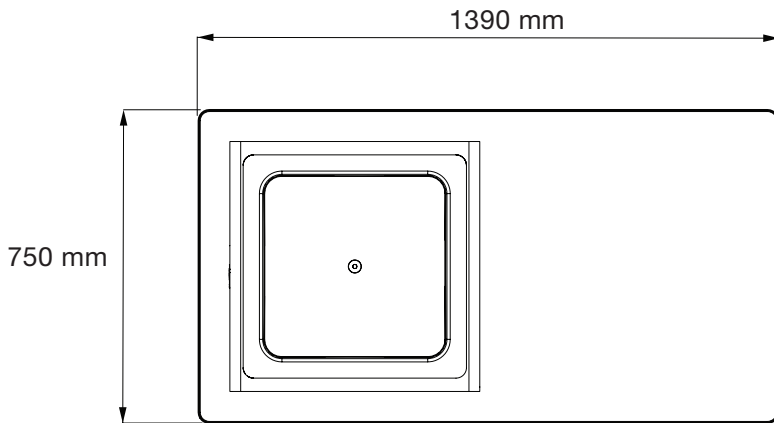

## CONFIGURATIONS:

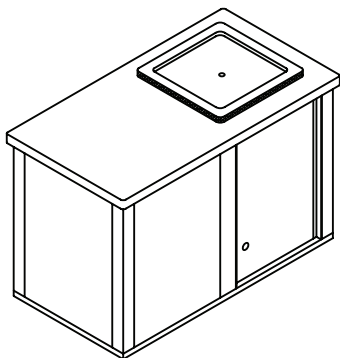

MOD-E-2.1 (Electric)  
MOD-G-2.1 (Gas)

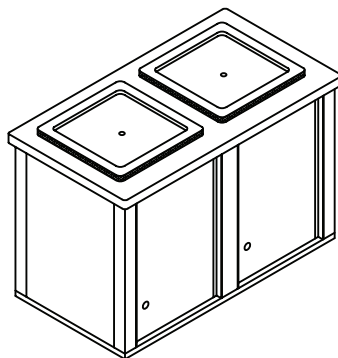

MOD-E-2.2 (Electric)  
MOD-G-2.2 (Gas)

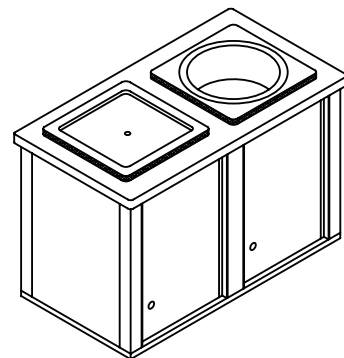

MOD-E-2.2:sink (Electric)  
MOD-G-2.2:sink (Gas)