

Instructions for wear checks of play equipment

The equipment must be checked for correct operation and safety, especially the points listed below:

Proof of maintenance

Playground.....

Date of installation

Checks depend on the type of equipment. Any equipment with moving parts must be checked at least twice a year, static equipment at least once a year.

Intervals for maintenance work and checks generally depend on

- location
- usage
- frequency of use
- possible vandalism

For more details see also "General instructions for maintenance of playgrounds".

Tractor Tyre Swing Order No. 7.45000

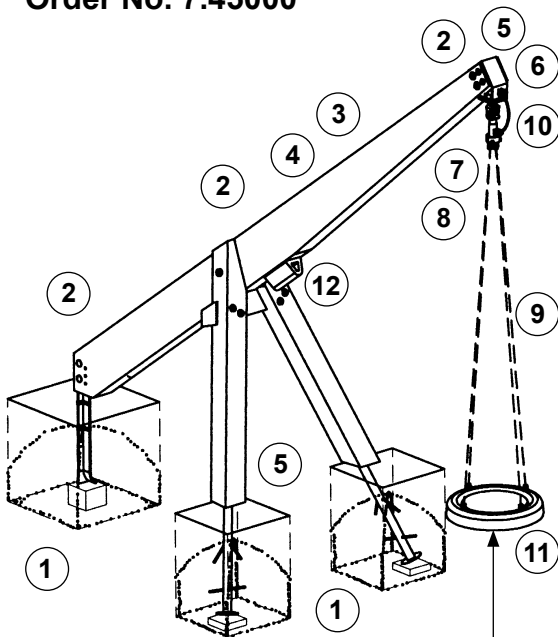

Check tyre for ground clearance of 40 cm.

Structural stability

1. Uncover the foundations once a year in order to check the structural stability as follows:
 - steel for corrosion
 - anchoring to the ground for stability
 - condition of concrete foundations
2. Check all bolts; retighten if necessary.

Wood

3. Check for rot and, if necessary, smooth out splinters and round off sharp edges & cracks.
4. Carefully check stability of laminated beam by pricking it with pointed, thin steel.
5. Recommendation: apply paraffin wax to the end grain areas once a year, especially near the ground; refer to order No. 0.90100, 1 litre.

Metal/ fittings

6. Check that universal joint moves smoothly in both directions.
7. Check that the ball bearing rotates freely; re-grease every 12 months.
8. Check chain suspension at the universal joint and at the tyre; first link of each chain must be locked.
9. Check chains: only a maximum of 1/3 of the material can be worn away; replace if necess.
10. Check safety cables; cable eye stiffeners must move freely.

Rubber

11. Check tyres for wear and tear as well as for vandalism; replace if required.
12. Replace fender profile (impact protection) if half of the material has been worn down.

Special notes, e.g. for repairs

Repair not carried out, it is still possible to play on equipment

Repair not carried out, equipment is taken out of action

All work carried out, everything is in order

Maintenance carried out by:







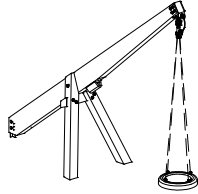

For spare parts refer to back of page.

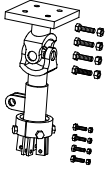
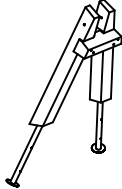
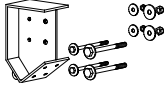
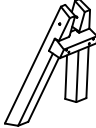
..... Date

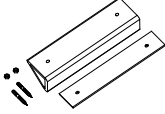
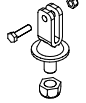
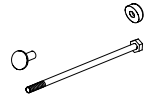
Spare parts
Tractor Tyre Swing
Order No. 7.45000

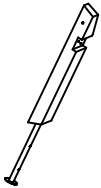
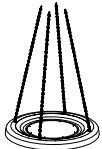
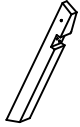

Please note that the safety standards of the equipment must not be affected. Therefore, when carrying out repairs it is helpful to **only use original parts.**

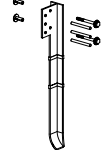
Order No. Spare part	Order No. Spare part
<p>0.93300 universal joint</p> 	<p>0.93430 A-frame without fixing bolt, with steel feet</p> 
<p>0.93310 mounting bracket for universal joint</p> 	<p>0.93431 A-frame without fixing bolt, pre-drilled for existing steel feet</p> 
<p>0.93320 safety cable for universal joint</p> 	<p>0.93470 fender profile for laminated beam</p> 
<p>0.93551 forked bolt for chain fastening</p> 	<p>0.93480 fixing bolt</p> 
<p>0.20020 stainless steel machine bolt</p> 	<p>99.01254 stand post, pre-drilled with steel foot</p> 
<p>0.93500 tyre with floor and 4 chains</p> 	<p>99.01210 stand post, pre-drilled for steel foot</p> 
<p>0.93510 tyre with floor without chains</p> 	<p>99.00600 cross beam for A-frame</p> 
<p>99.01274 floor Ø 60 cm, milled</p> 	
<p>0.93520 chain</p> 	
<p>0.93400 anchoring iron for laminated beam</p> 	
<p>0.93420 laminated beam with fender profile</p> 