

Instructions for wear checks of play equipment

The equipment must be checked for correct operation and safety, especially the points listed below:

Proof of maintenance

Playground.....

Date of installation

Checks depend on the type of equipment. Any equipment with moving parts must be checked at least twice a year, static equipment at least once a year.

Intervals for maintenance work and checks generally depend on

- the location
- the usage
- the frequency of use
- possible vandalism

For more details see also "General instructions for maintenance of playgrounds".

Stomach and Back Trainer
Order No. 11.50103

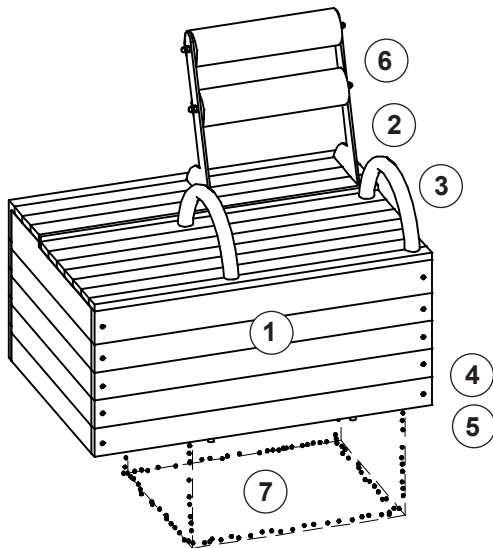

Wooden parts

1. Check for rot and, if necessary, smooth out splinters and round off sharp edges of cracks.

Resistance system

2. Check that the resistance system moves smoothly all the way to the stop without jerking.
3. Visually check rubber stop for cracks as well as for wear and tear, replace if necessary.
4. Ensure that radial damper consistently provides the set resistance.
5. Visually check spring for wear and tear, replace if necessary.

Back rest

6. Check that bolts and screws are tight and retighten if necessary.

Structural stability

7. Check the fixation to the ground once a year.

Special notes, e.g. for repairs

Repair not carried out, it is still possible to play on equipment

Repair not carried out, equipment is taken out of action

All work carried out, everything is in order

Maintenance carried out by:

..... Date